

1. On a separate sheet, draw the object shown here.  
Identify the drawing number, the class, and your name.

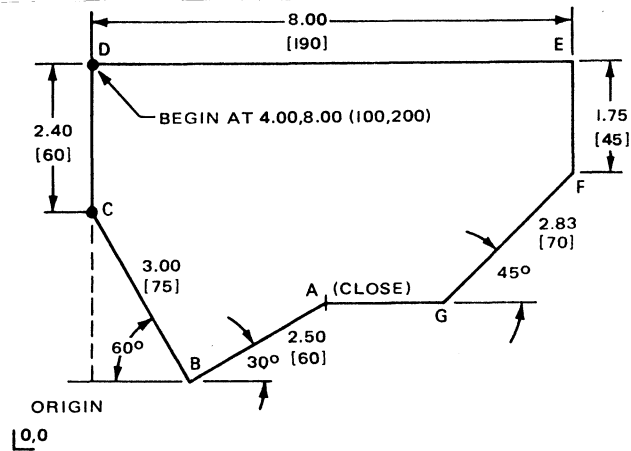

2. On a separate sheet, draw the object shown here.  
Identify the drawing number, the class, and your name.

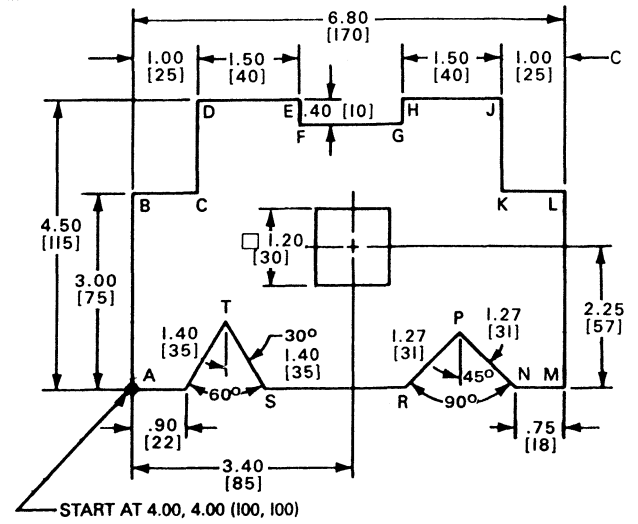

3. On a separate sheet, draw the object shown here.  
Identify the drawing number, the class, and your name.

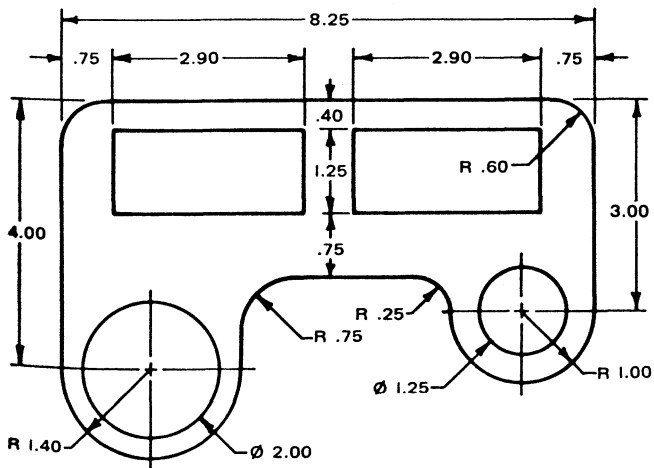

4. On a separate sheet, draw the object shown here.  
Identify the drawing number, the class, and your name.

